

Range: Modular detection for urinal
Ref: 52454 - Cellar detection - 2 to 6 urinals

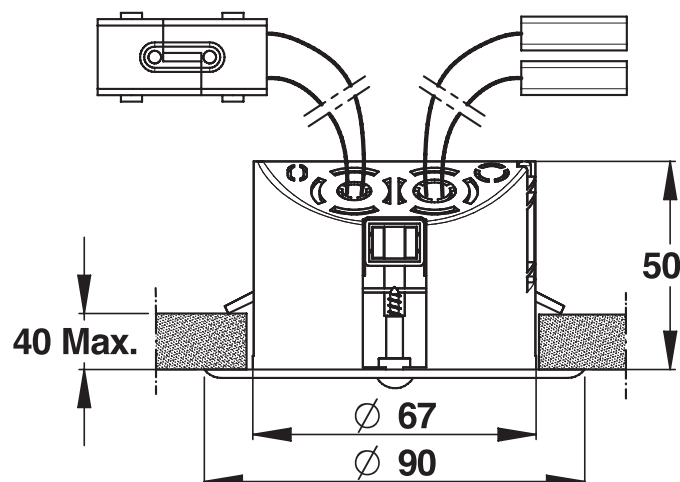

> Working pressure :

- 1 to 5 bar

> Flow :

- 104 l/min maximum à 3 bars
- Adjustable with stop valve

> Flow time :

- Rinsing time : 7 seconds is activated 30 seconds after the user leaves. Adjustable from 1 to 20 s.
- Pre-washing time equal to half the rinsing time, if activated

> Hydraulic supply :

- MM G 3/4" (20x27)

> Power supply :

- 10V AC- 230V AC/12V DC-12W electricity supply for installation in electrical cabinet on DIN rail

> Security :

- The 30-second timer is reinitialised if a new user arrives during this period
- Maximum duration of 2 minutes after which rinsing is forced (during intensive use).

> Delivered with :

- 1 Detector with control circuit
- 1 Solenoid valve with stop valve and filter
- 10V AC- 230V AC/12V DC-12W electricity supply for installation in electrical cabinet on DIN rail
- Instruction manual

> Standards & approvals :

- 200-hour neutral salt spray resistant (NSS) in accordance with ISO 9227

