

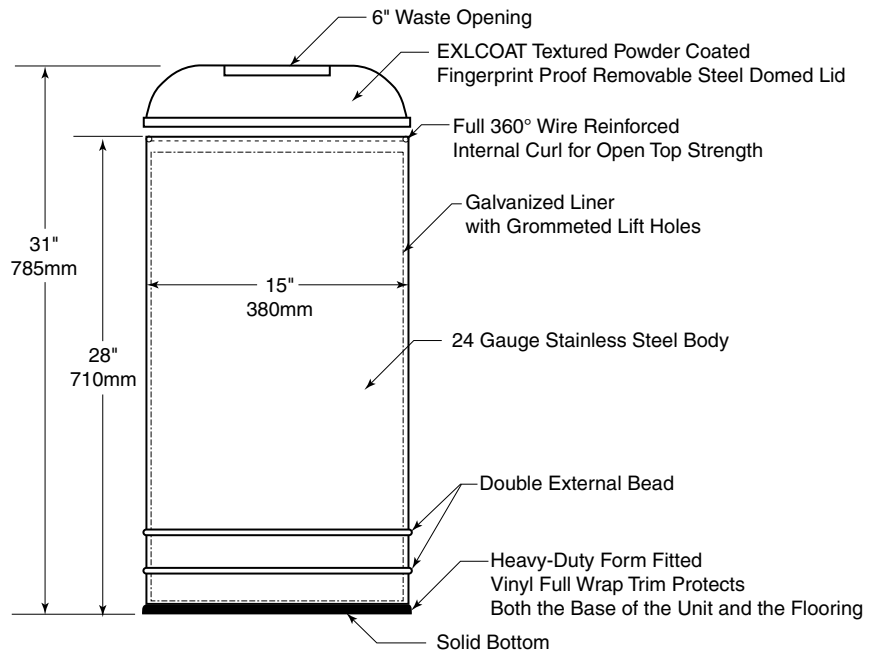

Technical Data

FLOOR-STANDING DOME-TOP WASTE RECEPTACLE

B-2300



MATERIALS:

Waste Receptacle — Floor-standing cylinder with solid bottom. Exposed surface has satin-finish. 24 gauge stainless steel body.

Dome-Top — Black cold-rolled steel. 6" (150mm) diameter opening has 1/2" (13mm) wide, contrasting metal rim that matches the finish on the waste receptacle.

Waste Container — Rigid plastic liner. Removable for servicing. Capacity: 18-gal. (68.1-L).

OPERATION:

Waste receptacle lifts off waste container for servicing. Wide opening provides hygienic, no-touch waste disposal.

Designer's Note: This unit is not suitable for outside use.

SPECIFICATION:

Floor-standing waste receptacle shall be stainless steel with satin-finish. Waste receptacle shall have an open bottom and a black steel dome-top secured with rivets to form a single structural unit. Dome-top shall have a 6" (150mm) diameter opening has 1/2" (13mm) wide, contrasting metal rim that matches the finish on the waste receptacle. Unit shall be furnished with a removable, rigid plastic liner that has a capacity of 18-gal. (68.1-L).

Floor-Standing Dome-Top Waste Receptacle shall be Model B-2300 of Bobrick Washroom Equipment, Inc., Clifton Park, New York; Jackson, Tennessee; Los Angeles, California; Bobrick Washroom Equipment Company, Scarborough, Ontario; Bobrick Washroom Equipment Pty. Ltd., Australia; and Bobrick Washroom Equipment Limited, United Kingdom.