

ARTICOLO / Item
Artículo / Article

02066

R1

Miscelatore a due pedali per montaggio a pavimento.

Foot operated mixer, floor mounted type.

Mezclador con doble pedal fijación al suelo.

Mitigeur à deux pédales fixation au sol.

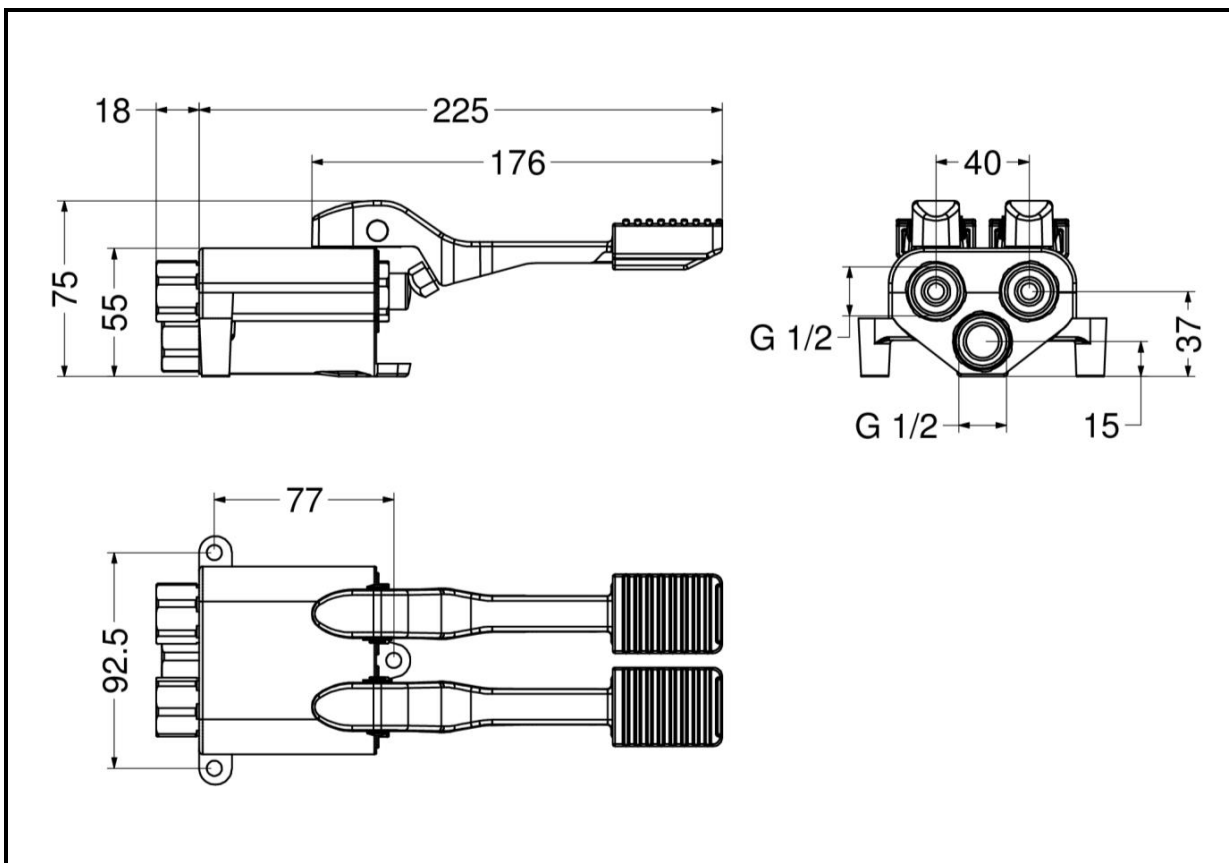
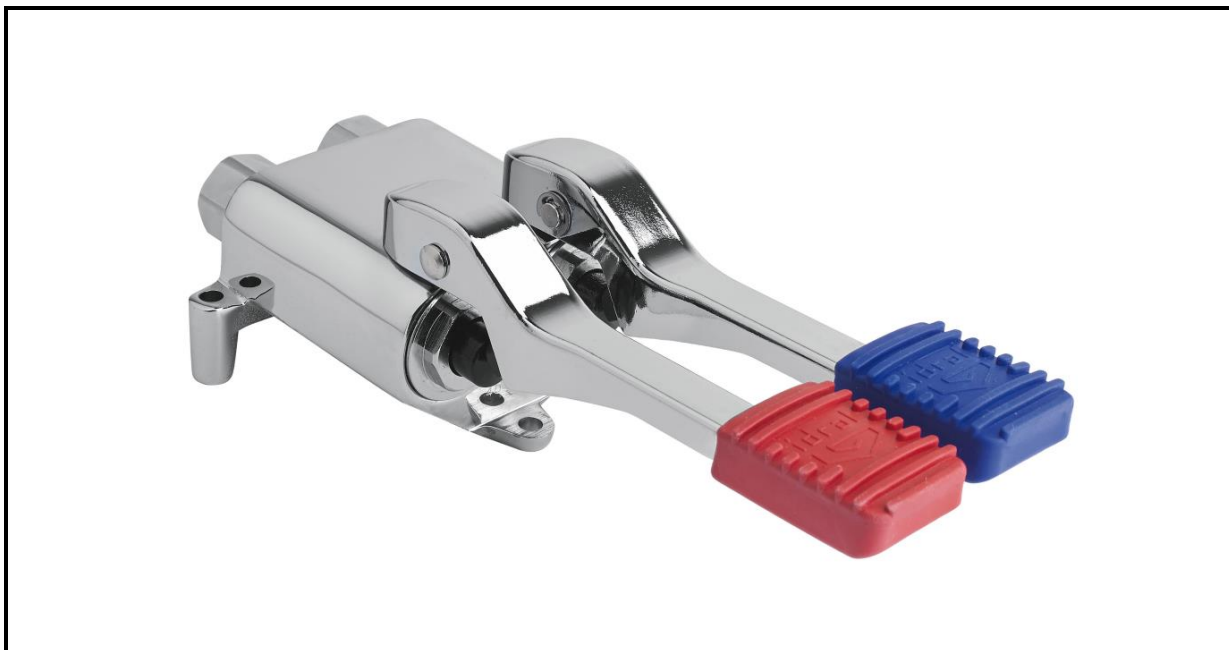

IT 

COMPOSIZIONE

- Corpo pedale in ottone cromato
- Leve in Zamak con copripedale in gomma
- Kit di fissaggio
- Guarnizioni con filtro 1/2"

CARATTERISTICHE FUNZIONALI

Pressione di alimentazione: Min 0.5 – max 8 bar

Temperatura di alimentazione: 5 – 65 °C

EN 

COMPOSITION

- Chromed brass tap's body
- Zamak levers with rubber cover
- Fixing kit
- 1/2" joints with filter

OPERATING CHARACTERISTICS

Operating pressure: Min 0.5 – max 8 bar

Water inlet temperature: 5 – 65 °C

ES 

CARACTERÍSTICAS

- Cuerpo pedal en latón cromado
- Palancas en Zamak y cobertura en goma
- Kit de fijación
- Juntas con filtro 1/2"

CARACTERÍSTICAS FUNCIONALES

Presión de alimentación: Min 0.5 – max 8 bar

Temperatura de alimentación: 5 – 65 °C

FR 

CARACTÉRISTIQUES

- Corps pédale en laiton chrome
- Leviers en Zamak avec couverture en caoutchouc
- Kit de fixation
- Joints avec filtre 1/2"

CARACTÉRISTIQUES FONCTIONNELLES

Pression d'alimentation: Min 0.5 – max 8 bar

Température d'alimentation: 5 – 65 °C

