

**ARTICOLO / Item**  
**Artículo / Article**

**02070**

Miscelatore progressivo monopedale per installazione a pavimento.

Foot operated progressive mixer, floor mounted type.

Mezclador progresivo monopedal para fijación suelo.

Mitigeur progressif avec un pédale, fixation au sol.

R1

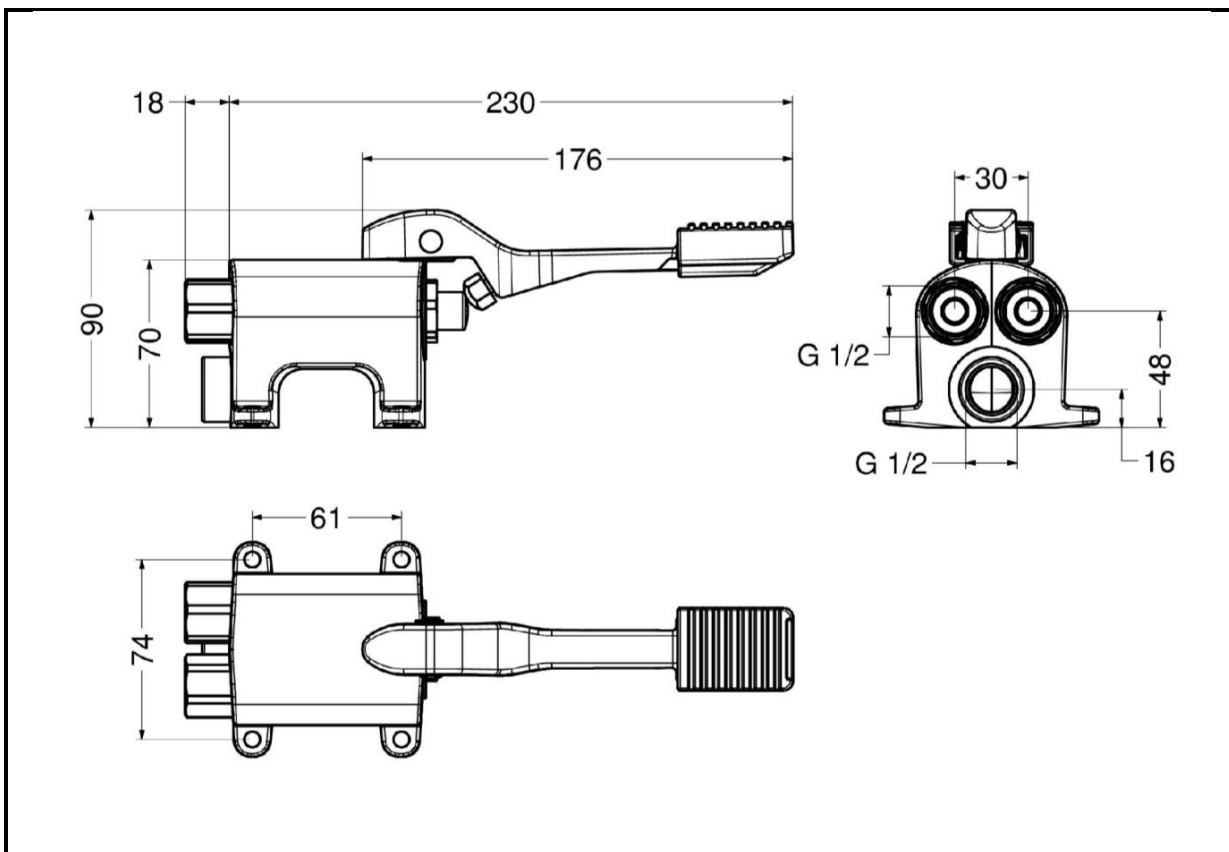

IT 

**COMPOSIZIONE**

- Corpo pedale in ottone cromato
- Leve in zamak con copripedale in gomma
- Kit di fissaggio
- Guarnizioni con filtro 1/2"

**CARATTERISTICHE FUNZIONALI**

**Pressione di alimentazione:** Min 0.5 – max 8 bar

**Temperatura di alimentazione:** 5 – 65 °C

EN 

**COMPOSITION**

- Chromed brass tap's body
- Zamak levers with rubber cover
- Fixing kit
- 1/2" joints with filter

**OPERATING CHARACTERISTICS**

**Operating pressure:** Min 0.5 – max 8 bar

**Water inlet temperature:** 5 – 65 °C

ES 

**CARACTERÍSTICAS**

- Cuerpo pedal en latón cromado
- Palancas en zamak y cobertura en goma
- Kit de fijación
- Juntas con filtro 1/2"

**CARACTERÍSTICAS FUNCIONALES**

**Presión de alimentación:** Min 0.5 – max 8 bar

**Temperatura de alimentación:** 5 – 65 °C

FR 

**CARACTÉRISTIQUES**

- Corps pédale en laiton chrome
- Leviers en zamak avec couverture en caoutchouc
- Kit de fixation
- Joints avec filtre 1/2"

**CARACTÉRISTIQUES FONCTIONNELLES**

**Pression d'alimentation:** Min 0.5 – max 8 bar

**Température d'alimentation:** 5 – 65 °C

