

BALTIC 230 F

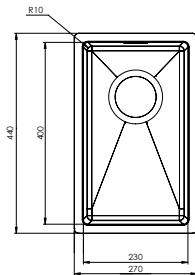

BALTIC 400 F

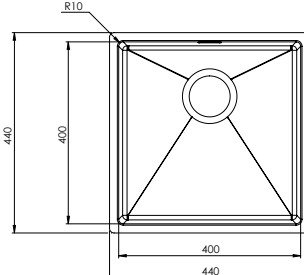

BALTIC 500 F

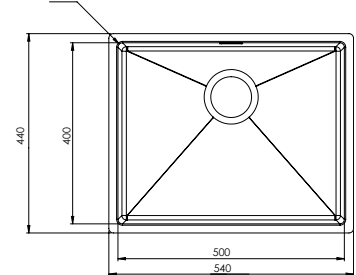

BALTIC 400 THF

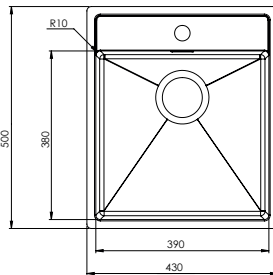

BALTIC 500 THF

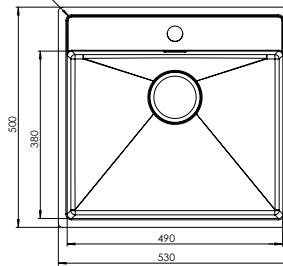

BALTIC 585 SHLF-LWT
BALTIC 585 SHRF-LWT

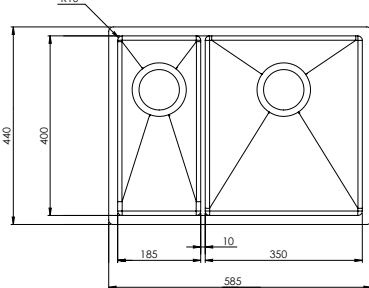

BALTIC 745 DF-LWT

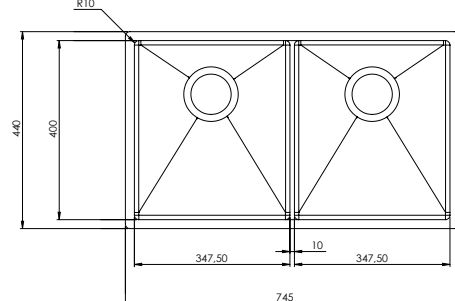

BALTIC 585 SHLF-LW
BALTIC 585 SHRF-LW

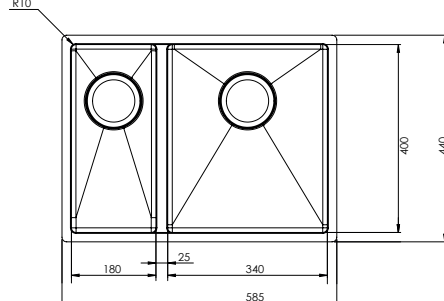

BALTIC 745 DF-LW

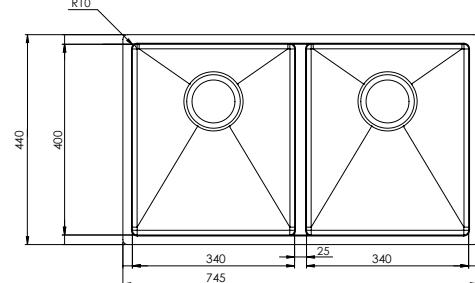

IntraBaltic

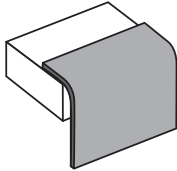

INCLUDED

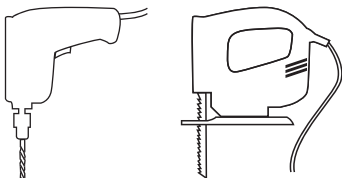
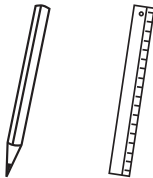
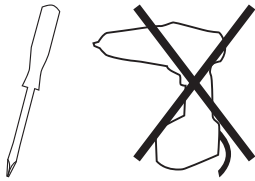
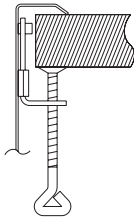

1

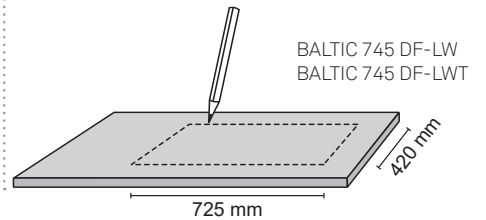
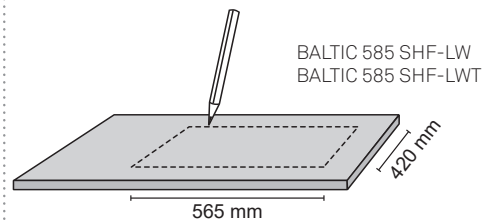
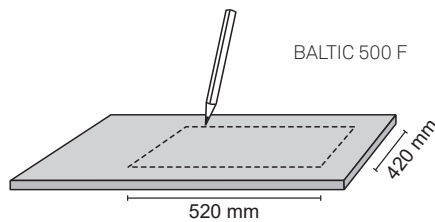
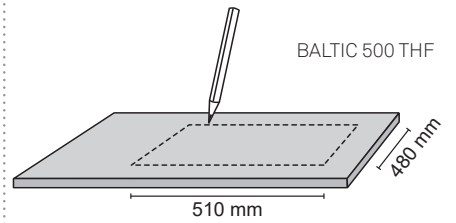
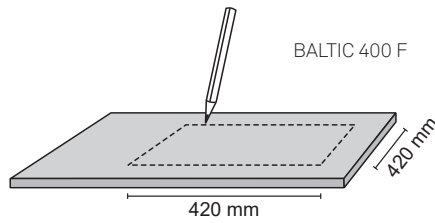
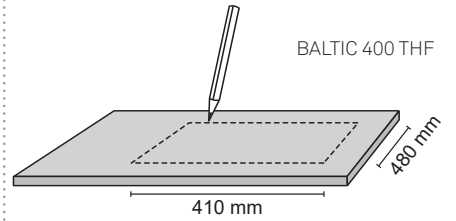
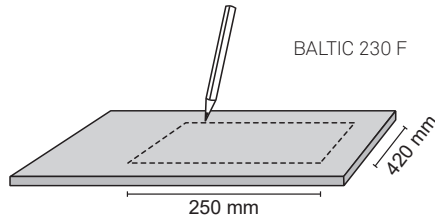

IntraBaltic

2

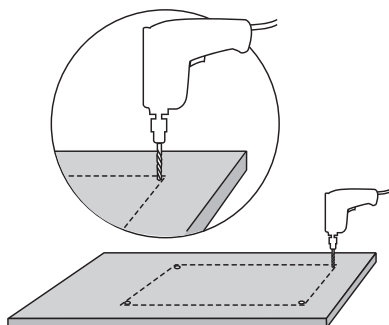

3

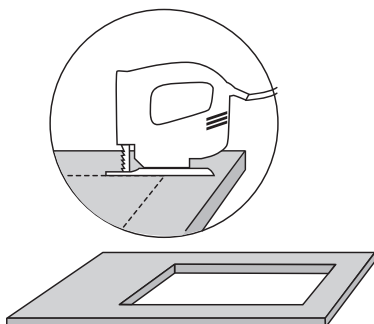

4

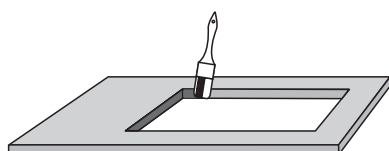

Försegl endetræet med silikone eller lignende.
Försegla snittytan i bänkskivan med silikon,
oljefärg eller dylikt.

5

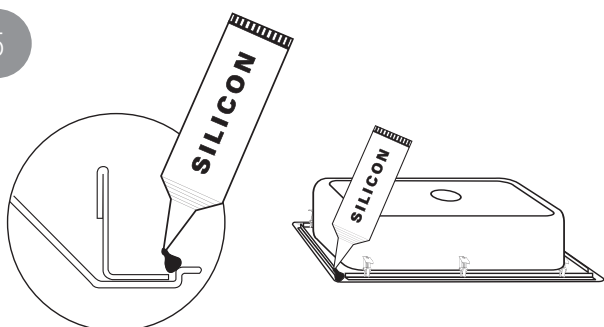

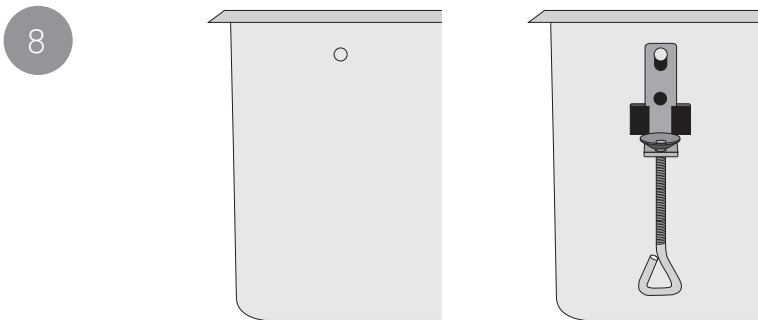
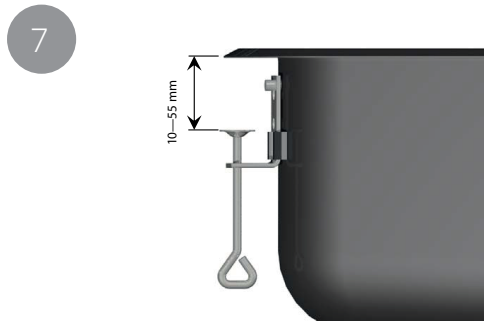
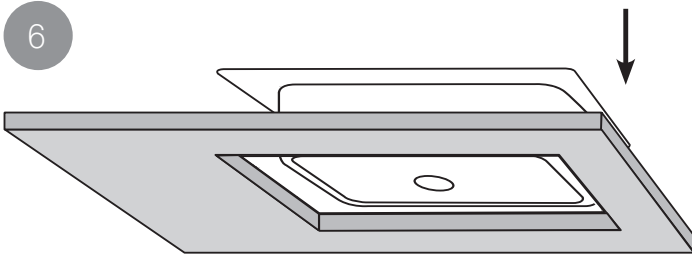

Bemærk! Denne type vaske er med påsvejst stift for montering. Der kan derfor forekomme mindre mærker indvendigt i kummen i forbindelse med påsvejsningen af stiften. Det er vigtigt at man i forbindelse med monteringen spænder beslagene forsigtigt for at undgå at lave buler eller mærker indvendigt i kummen.

Observera! Disklådan har påsvetsade stift som installationsmetod. Det kan därför förekomma mindre märken invändigt i disklådan. Spänn försiktigt vid montering för att undvika märken på insidan av disklådan.

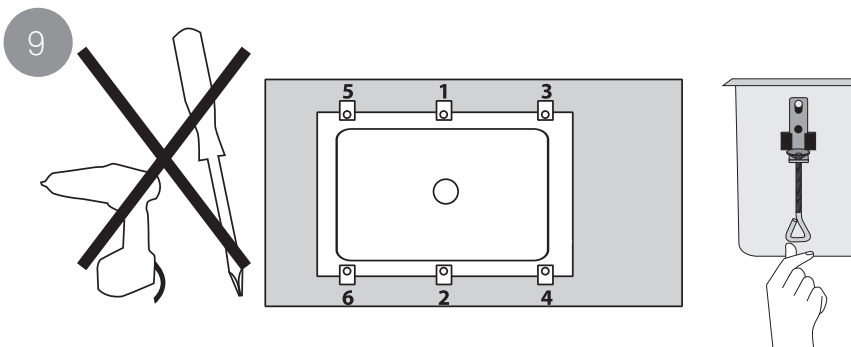

770640:2