

# TECHNICAL DATA SHEET

**PRESTO®**

**Range:** PRESTOTEM 2

**Ref:** 88830 - Shower panel with PRESTO TOUCH® and MASTERMIX® thermostatic tap, hand-held shower

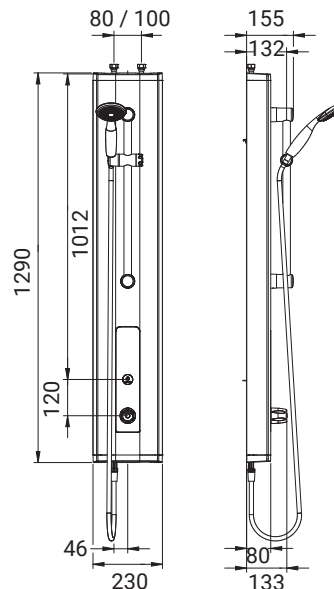

## > Working pressure :

- 1 to 5 bar

## > Flow rate:

- 6l/min with integrated flow limiter
- Anti-water-hammering device
- Hand-held shower on rail with chrome plated slide

## > Flow time:

- 30 seconds (adjustable from 1 sec to 5 min) and Start/Stop function
- Adjustable duration and frequency of the "duty flush" function

## > Hydraulic supply :

- G 1/2" (15x21), top or rear water inlet. For rear water inlet, we recommend to add the adaptation kit under the reference 91026
- On the PRESTO TOUCH® tapware and EN 1111 thermostatic mixer tap with NF check valves

## > Power supply:

- 6 V Lithium battery type CRP2 in a case integrated inside the panel

## > Material :

- Anodised aluminium extruded section (2.5mm thickness)
- Aluminium removable valve plate, painted RAL 7005 colour
- High resistance RAL 7005 coloured ABS covers

## > Functioning:

- Wide opening panel without the need to dismantle from the wall and shower taps on a removable valve plate

## > Thermal resistance :

- Resistant to a temperature of 70°C during 30 minutes (for 20 cycles) in case of thermal shocks

## > Security :

- WATER NETWORK SECURITY : no cross-connection between hot water and cold water (only in Mastermix technology). Two solenoid valves allow to isolate the hot water and cold water.
- ANTI-SCALDING SAFETY : flow is immediately stopped if the cold water or hot water is cut off, compliant to French norm EN1111. Integrated temperature switch limiter will not deliver pre-mixed water above 38°C.
- Possibility to parameter the periodical flushing in term of frequency or flow time
- The solenoid valve closes automatically if the battery runs out or the sensor is damaged

## > Delivered with :

- 1/2" hoses with revolving nuts
- MM 1/2" (15x21) straight stop valves and 250 micron filters
- Fastening screws and instruction manual

## > Standards & approvals :

- Brass body in accordance with EN 1982, EN 12164, EN 12165
- Chrome-plated surface treatment in accordance with EN 12540
- 200-hour neutral salt spray resistant (NSS) in accordance with ISO 9227



