

TECHNICAL DATA SHEET

PRESTO®

Range: SO'O

Ref: 56196 - Deck-mounted mixer sensor tap - Battery - Black and pink gold cover

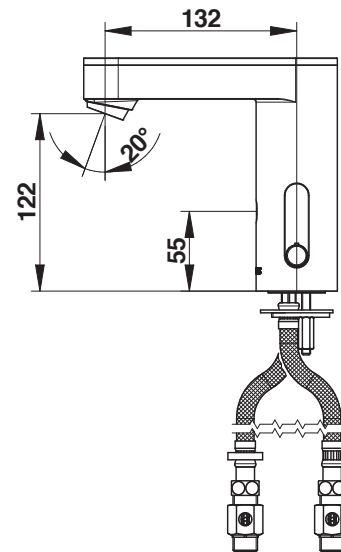

> Working pressure :

- 1 to 5 bar

> Flow :

- 3 l/min with integrated flow regulator
- High quality anti-limescale aerator
- Anti-water-hammering design

> Hydraulic supply :

- G 3/8" (12x17)

> Power supply :

- 6 V lithium battery (CRP2 type) in a casing placed within the tap body

> Material and colour finish :

- Chrome-plated metal alloy components
- Injected molded metal body and cover
- Black finish with pink gold cover

> Thermal resistance :

- Resistant to a temperature of 75°C for 30-minute-thermal-shocks

> Security :

- Temperature limited by adjustable stop
- Anti-overflow security time: 30 seconds
- Anti-blocking system preventing the water to flow continuously
- Solenoid valve automatically shut down in case of power shortage or in case of sensor degradation

> Delivered with:

- 2 Fastening nuts
- 1 Gasket and 1 Washer
- 2 PEX flexible hoses with F 3/8" nut (12x17) and NF non-return valve
- 2 Straight stop valves G 3/8" (12x17)
- 2 Filter gaskets
- Instructions manual

> Standards & approvals :

- 200-hour neutral salt spray resistant (NSS) in accordance with ISO 9227

Ce document n'est pas contractuel ; nous réservons le droit de modifier les caractéristiques de nos produits sans préavis. Toutes nos marques et tous modèles sont déposés.

